

Introduction

This user manual describes the STEVAL-IFS010V1 STR9 ZigBee® demonstration board hardware. As well as the block diagram and schematics of the demonstration board, a bill of materials and assembly instructions are also included.

The STR9 ZigBee demonstration board provides SN260 ZigBee with interface to an application running on host processor. Please note that the demonstration board cannot be used in standalone mode without a host processor.

The SN260 integrates a 2.4 GHz, IEEE 802.15.4-compliant transceiver with a 16-bit network processor (XAP2b core) to run EmberZNet™, the ZigBee-compliant network stack. The SN260 accesses the EmberZNet API across a standard SPI module, allowing application development on a host processor. This means that the SN260 can be viewed as a ZigBee peripheral connected over a SPI. The XAP2b microprocessor is a power-optimized core integrated in the SN260. It contains integrated Flash and RAM memory along with an optimized peripheral set to enhance the operation of the network stack. Refer to STMicroelectronics™ SN260 datasheet for additional information. This user manual must be read in conjunction with user manual UM0282 describing the STR9 dongle. These documents are available on www.st.com.

Figure 1. STR9 ZigBee demonstration board

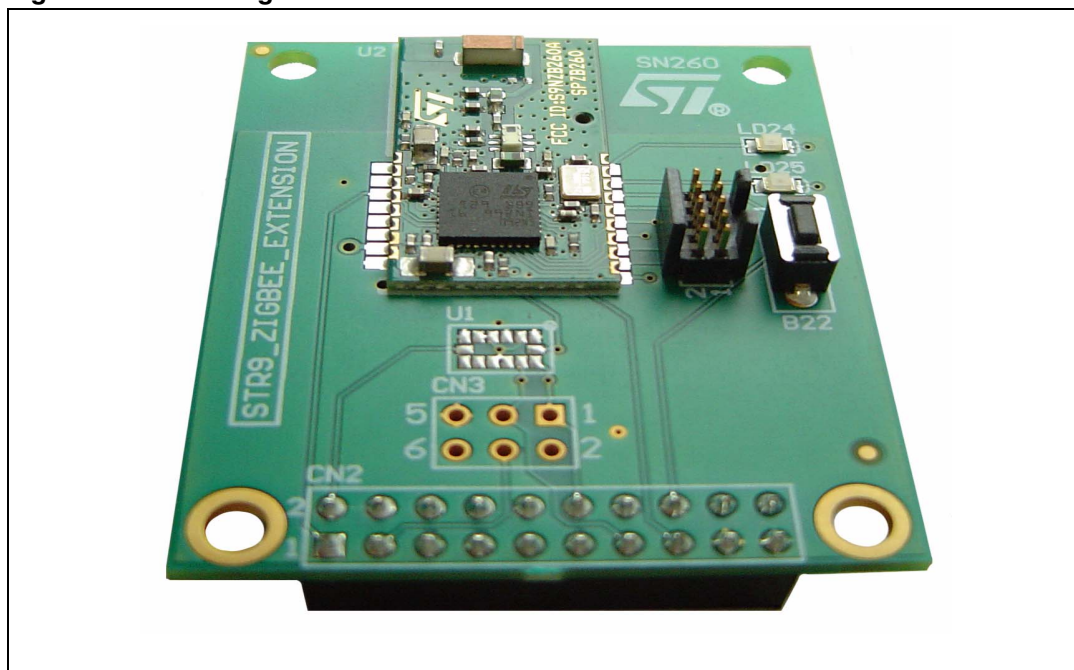

Contents

| | | |
|---|--|---|
| 1 | Block diagram | 3 |
| 2 | Schematics | 4 |
| 3 | PCB layout | 5 |
| 4 | Bill of material | 6 |
| 5 | Connection of STR9 ZigBee demonstration board to STR9 dongle . . . | 7 |
| 6 | Revision history | 8 |

1 Block diagram

This demonstration board is based on the STR9 dongle.

The main board features are the following:

- SPZB260 radio communication module based on SN260 ZigBee network processor
- Digital interfaces:
 - 16 general purpose I/Os (GPIOs)
 - One I²C bus interface
 - Two SPI bus interfaces of which one is used to interface with the STR9 dongle and the other is available to extend the board with another SPI device
 - 2 external interrupts
- Digital MEMS in LGA14 package (optional)
- A debug port
- 1 button and 2 LEDs

Note: The power supply is delivered by the STR9 dongle.

Figure 2 shows the STR9 ZigBee demonstration board block diagram.

Figure 2. STR9 ZigBee demonstration board block diagram

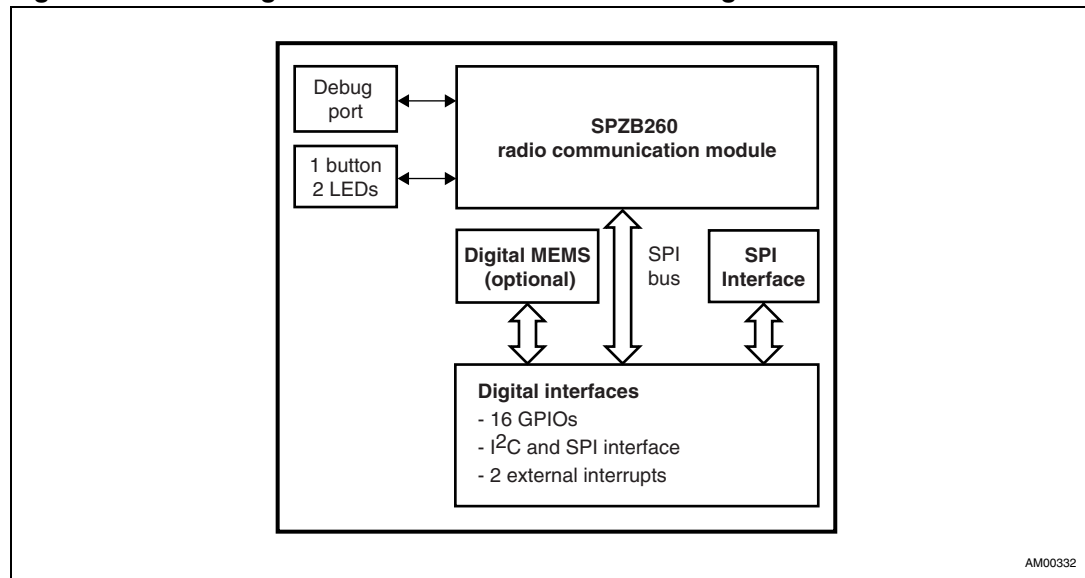

2 Schematics

Figure 3. STR9 ZigBee demonstration board schematic

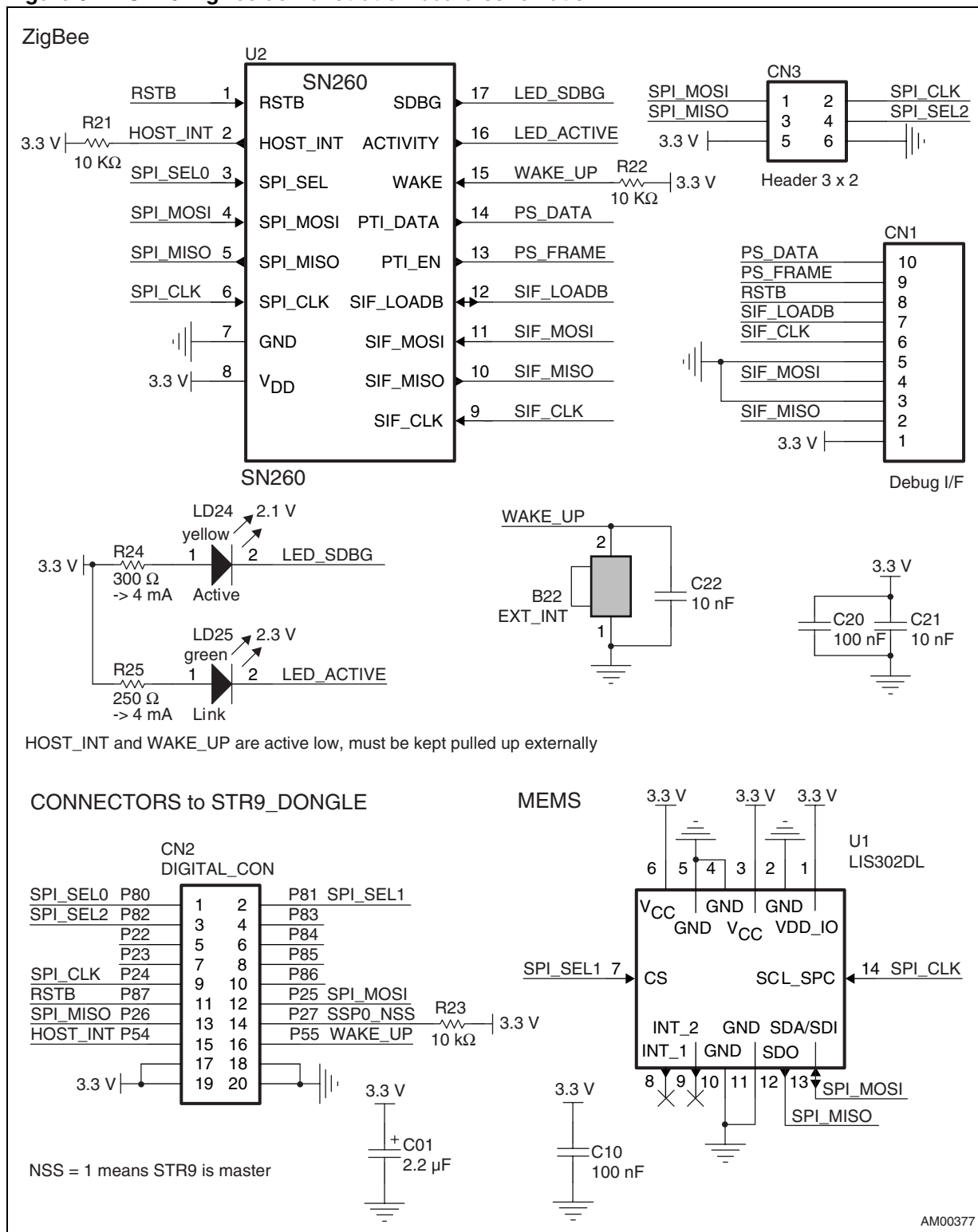

4 Bill of material

[Table 1](#) shows the bill of material, while [Section 5](#) provides additional information on how to connect the STR9 ZigBee demonstration board to the STR9 dongle.

Table 1. Bill of material

| Designator | Footprint | Description | Assembled | Order code |
|---------------|---------------------------|----------------------------------|-----------|---------------------------------------|
| B22 | DT2112C | EXT_INT button | Yes | GM [®] Electronic: P-DT2112C |
| C01 | AB | 2.2 μ F | Yes | Farnell: 757-720 (STD, 10 V) |
| C10, C20 | 0805 | 100 nF | Yes | Farnell: 422-7189 (X7R, 50 V) |
| C21, C22 | 0805 | 10 nF | Yes | Farnell: 422-7153 (X7R, 50 V) |
| CN1 | 1.27 mm 2 x 5 pin header | Debug I/F | Yes | Samtec: FTSH-114-04-F-DV |
| CN2 | 2.54 mm 2 x 10 pin header | DIGITAL_CON | Yes | GM: BL220G |
| CN3 | 2.54 mm 2 x 3 pin header | SPI connector | Yes | GM: S2G20 |
| LD24 | 0805 | yellow LED diode | Yes | GM: 960-025 |
| LD25 | 0805 | green LED diode | Yes | GM: 960-023 |
| R21, R22, R23 | 0805 | 10 K Ω | Yes | GM: R0805-10K |
| R24 | 0805 | 300 Ω | Yes | GM: R0805-300R |
| R25 | 0805 | 250 Ω | Yes | GM: R0805-250R |
| U1 | LGA14AD | LIS302DL | Yes | ST: LIS302DL |
| U2 | SN260 | SN260 radio communication module | Yes | ST: SPZB260 |

5 Connection of STR9 ZigBee demonstration board to STR9 dongle

This section provides additional information on how to connect the STR9 ZigBee demonstration board to the STR9 dongle (see [Figure 3](#)).

- SPI chip select inputs (active low)
There are 3 SPI chip select inputs:
 - SPI_SEL0: this input is used to select the ZigBee module. It is connected to P80 pin of the STR9 dongle.
 - SPI_SEL1: this inputs is used to select the MEMS. It is connected to P81 pin of the STR9 dongle.
 - SPI_SEL2: this input is used to select the external device if any. It is connected to P82 pin of the STR9 dongle.
- HOST_INT output (active low)
The SN260 ZigBee processor generates an interrupt to the host processor (STR912xx) on the falling edge of HOST_INT. This signal is connected to P45 pin on the STR9 dongle which must be configured as an input with interrupt capability.
- WAKE_UP input (active low)
This input performs the wake up of the SN260 ZigBee processor. It is connected both to P55 pin of the STR9 dongle and to B22 button.
 - If P55 is configured as an output, the ZigBee device can be woken up either by a falling edge on the signal connected to P55 pin or by pressing B22 button.
 - If P55 is configured as an input with interrupt capability, a falling edge on the signal connected to P55 wakes up the ZigBee device and an interrupt to the STR9 dongle is generated by pressing B22 button.

6 Revision history

Table 2. Document revision history

| Date | Revision | Changes |
|-------------|----------|--|
| 28-Aug-2007 | 1 | Initial release. |
| 03-Apr-2008 | 2 | Updated <i>Figure 1: STR9 ZigBee demonstration board</i> . |
| 05-Mar-2009 | 3 | Renamed “extension board” to “demonstration board”, updated <i>Introduction</i> , <i>Figure 1: STR9 ZigBee demonstration board</i> , <i>Figure 2: STR9 ZigBee demonstration board block diagram</i> , <i>Figure 3: STR9 ZigBee demonstration board schematic</i> , <i>Section 5</i> , reformatted <i>Table 1: Bill of material</i> . |

Please Read Carefully:

Information in this document is provided solely in connection with ST products. STMicroelectronics NV and its subsidiaries ("ST") reserve the right to make changes, corrections, modifications or improvements, to this document, and the products and services described herein at any time, without notice.

All ST products are sold pursuant to ST's terms and conditions of sale.

Purchasers are solely responsible for the choice, selection and use of the ST products and services described herein, and ST assumes no liability whatsoever relating to the choice, selection or use of the ST products and services described herein.

No license, express or implied, by estoppel or otherwise, to any intellectual property rights is granted under this document. If any part of this document refers to any third party products or services it shall not be deemed a license grant by ST for the use of such third party products or services, or any intellectual property contained therein or considered as a warranty covering the use in any manner whatsoever of such third party products or services or any intellectual property contained therein.

UNLESS OTHERWISE SET FORTH IN ST'S TERMS AND CONDITIONS OF SALE ST DISCLAIMS ANY EXPRESS OR IMPLIED WARRANTY WITH RESPECT TO THE USE AND/OR SALE OF ST PRODUCTS INCLUDING WITHOUT LIMITATION IMPLIED WARRANTIES OF MERCHANTABILITY, FITNESS FOR A PARTICULAR PURPOSE (AND THEIR EQUIVALENTS UNDER THE LAWS OF ANY JURISDICTION), OR INFRINGEMENT OF ANY PATENT, COPYRIGHT OR OTHER INTELLECTUAL PROPERTY RIGHT.

UNLESS EXPRESSLY APPROVED IN WRITING BY AN AUTHORIZED ST REPRESENTATIVE, ST PRODUCTS ARE NOT RECOMMENDED, AUTHORIZED OR WARRANTED FOR USE IN MILITARY, AIR CRAFT, SPACE, LIFE SAVING, OR LIFE SUSTAINING APPLICATIONS, NOR IN PRODUCTS OR SYSTEMS WHERE FAILURE OR MALFUNCTION MAY RESULT IN PERSONAL INJURY, DEATH, OR SEVERE PROPERTY OR ENVIRONMENTAL DAMAGE. ST PRODUCTS WHICH ARE NOT SPECIFIED AS "AUTOMOTIVE GRADE" MAY ONLY BE USED IN AUTOMOTIVE APPLICATIONS AT USER'S OWN RISK.

Resale of ST products with provisions different from the statements and/or technical features set forth in this document shall immediately void any warranty granted by ST for the ST product or service described herein and shall not create or extend in any manner whatsoever, any liability of ST.

ST and the ST logo are trademarks or registered trademarks of ST in various countries.

Information in this document supersedes and replaces all information previously supplied.

The ST logo is a registered trademark of STMicroelectronics. All other names are the property of their respective owners.

© 2009 STMicroelectronics - All rights reserved

STMicroelectronics group of companies

Australia - Belgium - Brazil - Canada - China - Czech Republic - Finland - France - Germany - Hong Kong - India - Israel - Italy - Japan - Malaysia - Malta - Morocco - Singapore - Spain - Sweden - Switzerland - United Kingdom - United States of America

www.st.com